

TECHNICAL DATA

tactic 112 A, tactic 212 A

Dimensional drawings

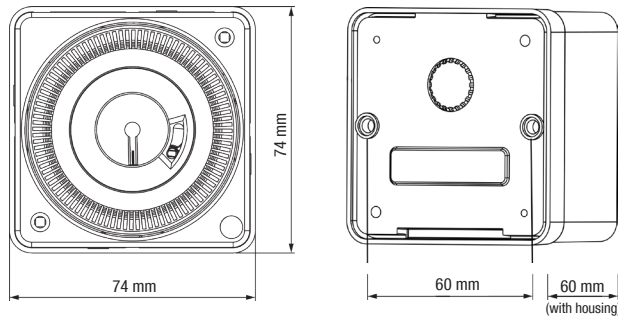

Connection example

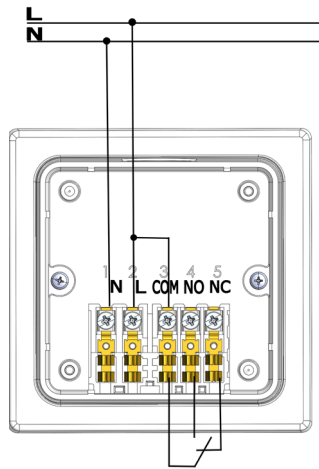

GRÄSSLIN



Technical changes, improvements and printing errors excepted 202604

GRÄSSLIN

Grässlin Zeitschaltechnik GmbH
Leopoldstrasse 1
78112 St. Georgen | Germany
Tel. +49 (0) 7724/933-0
info@graesslin.de | www.graesslin.de

Insect-proof housing

Your timer modules now optimally protected





SWITCHING TECHNOLOGY

MAINS SYNCHRONOUS OR QUARTZ

Mains synchronous:

- ▶ Very stable over long periods (mains compensates for fluctuations)
- ▶ No time deviation in continuous operation
- ▶ Ideal for applications that run continuously

Quartz:

- ▶ Precise time measurement ($\leq \pm 1$ second/day)
- ▶ Independent of the power grid
- ▶ Continues to run even during a power outage

SMALL CAUSE

BIG EFFECT

If it's crawling and creeping everywhere again, we have the perfect solution for you. The popular flat module tactic will soon be available with an insect protection housing. It is often the small pests that disable timer modules by penetrating the inside of the housing. With our new insect-proof housing, this problem is a thing of the past. Longer protection and increased service life

Longer protection and increased service life

Grässlin time switches are used on many continents worldwide. That is why we have developed an insect-proof housing that protects your timer modules from all kinds of insects. The result: your valuable modules last significantly longer and remain functional, no matter what environment they are used in. Trust in our quality and optimally protect your devices from unwanted guests!

- ▶ Effective protection against insects
- ▶ Avoidance of failures
- ▶ Higher operational reliability

More protection. Fewer malfunctions. Maximum reliability.

No more crawling pests

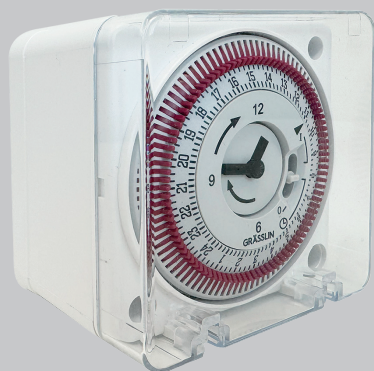

tactic 112A/212A



tactic 112 A

- ▶ Analog universal time switch with synchronous motor for wall mounting
- ▶ Insect-proof housing
- ▶ Daily program
- ▶ 1 channel
- ▶ Time accuracy: mains synchronous
- ▶ Without power reserve
- ▶ Art. No. 01.78.1002.1

tactic 212 A

- ▶ Analog universal time switch with quartz drive for wall mounting
- ▶ Insect-proof housing
- ▶ Daily program
- ▶ 1 channel
- ▶ Time accuracy: $\leq \pm 1$ s/day
- ▶ Power reserve: 3 days
- ▶ Art. No. 02.78.1004.1

